

# Physics ATAR - Year 11

## Electrical Physics Unit Test 2017

Name:
-------

Mark:	/ 63
=	%

Time Allowed: 50 minutes

Notes to Students:

- You must include **all** working to be awarded full marks for a question.
- Marks will be deducted for incorrect or absent units and answers stated to an incorrect number of significant figures.
- **No** graphics calculators are permitted – scientific calculators only.

**Question 1****(7 marks)**

During a laboratory practical session, James connects a simple light circuit to a 12.0 V DC power supply.

- (a) Calculate the work done in Joules as one electron travels around the circuit.

(2 marks)

$$V = \frac{W}{q}, W = Vq \quad (0.5)$$

$$W = (12.0)(1.60 \times 10^{-19}) \quad (0.5)$$

$$W = 1.92 \times 10^{-18} \text{ J} \quad (1)$$

- (b) Calculate the charge that passes through the circuit in 2.00 minutes if the current through the circuit is 0.500 A.

(3 marks)

$$I = \frac{q}{t}, q = It \quad (1)$$

$$q = (0.500)(2 \times 60) \quad (1) \text{ (No mark awarded if } 2 \times 60 \text{ not shown)}$$

$$q = 60.0 \text{ C} \quad (1)$$

- (c) Calculate the number of electrons that are required to pass through the circuit to produce the charge in (b).

(2 marks)

$$n = \frac{60}{1.60 \times 10^{-19}} = 3.75 \times 10^{20} \text{ electrons} \quad (1 \text{ mark working, 1 mark answer})$$

**Question 2****(8 marks)**

A car battery supplies a voltage of 12.6 V. It is connected in parallel to the dashboard lights (which have a total resistance of 7.12 k $\Omega$ ) and the headlights (which have a total resistance of 6.00  $\Omega$ ).

- (a) Draw a simple circuit diagram to represent this arrangement.

(2 marks)

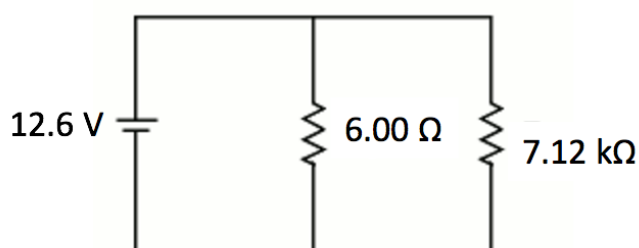

Uses appropriate symbols (1)

All components labelled (1)

Also accepted, 2 resistors of 6.00  $\Omega$  in parallel for headlights.

- (b) Calculate the potential difference across and current through the headlight bulbs. (3 marks)

$$V = 12.6 \text{ V} \quad (1 \text{ mark})$$

$$I_{\text{headlights}} = \frac{V_{\text{headlights}}}{R_{\text{headlights}}} \quad (1 \text{ Equation})$$

$$I_{\text{headlights}} = \frac{12.6}{6.00} = 2.10 \text{ A} \quad (0.5 \text{ working, } 0.5 \text{ answer})$$

- (c) Determine the power of the **dashboard** lights. (3 marks)

$$P = \frac{V^2}{R}, (V = IR, P = VI) \quad (1 \text{ mark equation})$$

$$P = \frac{12.6^2}{7.12 \times 10^3} = 22.3 \text{ mW} \quad (22.3 \times 10^{-3} \text{ W}) \quad (1 \text{ mark working, } 1 \text{ mark answer})$$

### Question 3 (6 marks)

Tungsten filament light globes are classified as non-ohmic devices.

- (a) With the aid of two graphs, describe the differences between the current, voltage and resistance characteristics of ohmic and non-ohmic devices. (3 marks)

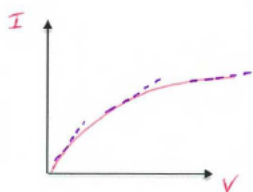
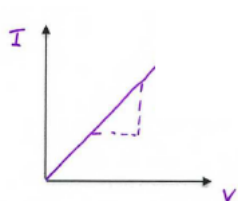

0.5 mark each for each diagram showing linear and non linear relationships

Ohmic

Non-Ohmic

- Ohmic devices, current varies linearly with voltage (or, resistance is fixed) (1)
- Non ohmic, current varies non linearly with voltage (or, resistance changes) (1)

No marks for “obeys” or “disobeys” Ohm’s law

- (b) Older tungsten filament light globes often fail just as they are turned on, explain why this is so. (3 marks)

- When turned on, temperature is low
- Temperature is related to resistance, therefore resistance is low
- A large rush of current can cause failure

**Question 4****(7 marks)**

The following questions refer to the below circuit diagram, where 'R' represents a resistor of resistance ' $R \Omega$ '. Leave all your responses in terms of 'R' if applicable. You may leave your answer as a fraction or decimal.

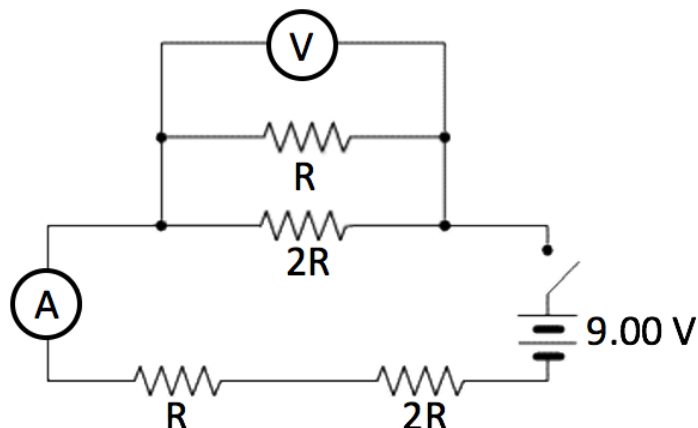

- (a) When the switch is closed, calculate the current displayed by ammeter A. (5 marks)

$$\frac{1}{R_{R//2R}} = \frac{1}{R} + \frac{1}{2R} = \frac{2}{2R} + \frac{1}{2R} = \frac{3}{2R}$$

(1 mark working for parallel resistor)

$$R_{R//2R} = \frac{2R}{3}$$

(1 mark answer for parallel resistance)

$$R_T = \frac{2R}{3} + R + 2R = 3.67R \text{ or } \frac{11R}{3} \Omega$$

(1 mark for solving series resistance)

$$I_T = \frac{V_T}{R_T}$$

(0.5 Equation)

$$I_T = \frac{9}{\left(\frac{11R}{3}\right)}$$

(0.5 Working for  $I_T$ )

$$I_T = \frac{27}{11R} A \text{ or } \frac{2.54}{R} A$$

(1 mark solving/ simplifying  $I_T$ )

- (b) When the switch is closed, calculate the voltage displayed on Voltmeter V. (2 marks)

$$V = I_T R_{R//2R}$$

(0.5 Equation)

$$V = \frac{27}{11R} \times \frac{2R}{3}$$

(0.5 Working)

$$V = 1.64 V$$

(1 mark answer)

**Question 5****(10 marks)**

An electric heater is constructed by applying a potential difference of  $1.20 \times 10^2 \text{ V}$  to a Nichrome wire that has a total resistance of  $8.00 \Omega$ .

(a) Determine the current carried by the wire.

(2 marks)

$$I = \frac{V}{R}$$

(0.5 equation, 0.5 working, 1 answer)

$$I = \frac{120}{8.00} = 15.0 \text{ A}$$

(b) Determine the power rating of the heater.

(2 marks)

$$P = VI = 120 \times 15 = 1800 = 1.80 \text{ kW}$$

(0.5 equation, 0.5 working, 1 answer)

(c) If the heater is used for 3.00 hours each night for a week and the consumer pays 15.0 c per kilowatt hour for energy purchased, determine the cost of running the heater over one week.

(3 marks)

$$E = P.t \text{ ( or Number of kW x no of hours)}$$

(0.5 mark equation)

$$= (1.80) \times (3) \times (7)$$

(0.5 mark full working, no mark if 3 x 7 not shown)

$$= 37.8 \text{ kWh}$$

(0.5 mark no. of units calculated)

$$\text{Cost} = \text{No of Units} \times \text{Cost per Unit}$$

(0.5 mark equation)

$$= 37.8 \times 0.15$$

(0.5 mark working)

$$= \$5.67$$

(0.5 mark solution)

(d) A different Nichrome wire has a diameter of 1.30 mm. Calculate the length of wire needed to obtain a resistance of  $4.00 \Omega$ . ( $\rho_{\text{Nichrome}} = 1.50 \times 10^{-6} \Omega\text{m}$ ,  $R = \frac{\rho L}{A}$ )

(3 marks)

$$A = \frac{\pi \phi^2}{4} = \frac{\pi(1.30 \times 10^{-3})^2}{4} = 1.327 \times 10^{-6} \text{ m}^2$$

(1 mark calculates area)

$$R = \frac{\rho L}{A} \quad L = \frac{RA}{\rho}$$

(0.5 mark equation)

$$L = \frac{(4.00)(1.327 \times 10^{-6})}{1.50 \times 10^{-6}} = 3.54 \text{ m}$$

(0.5 mark working, 1 mark solution)

**Question 6****(10 marks)**

While investigating an electricity failure in a workshop it becomes apparent that a fuse has melted within the main electrical panel, leaving an open circuit and preventing charge from flowing. In order to restore the electricity, an operator places a small piece of iron between the two open terminals in order to allow the flow of charge. This enables the workshop to keep operating as per normal.

(a) Explain why this was not an appropriate fix for this problem and justify your response. (4 marks)

- A fuse is designed to protect the circuit in the event of excess current
- If the fuse has melted, there must be some fault in the system which remains unrectified (short or similar)
- By replacing with a conductor potentially excessive charge will be able to flow (or fuse is overrated)
- Causing damage to the circuits / potential for fire

(b) Fuses are being phased out of household use. Name an alternative common safety device that performs the same function as a fuse and describe how it functions. (3 marks)

- Circuit breaker
- An electromechanical device (detects electrical input → mechanical switch output)
- Opening the circuit in fault conditions

During a storm, the workshop can sometimes become flooded. This creates an additional hazard due to water potentially coming into contact with live wires.

(c) Explain why water is considered an electrical hazard. (3 marks)

- Water contains impurities (dissolved salts, ions)
- Which can easily carry charge / conduct a current / become live
- Posing a risk of electrocution if humans come into contact with it

**Question 7****(15 marks)**

Refer to the circuit diagram below. Note you must show full and clear working to receive full marks.

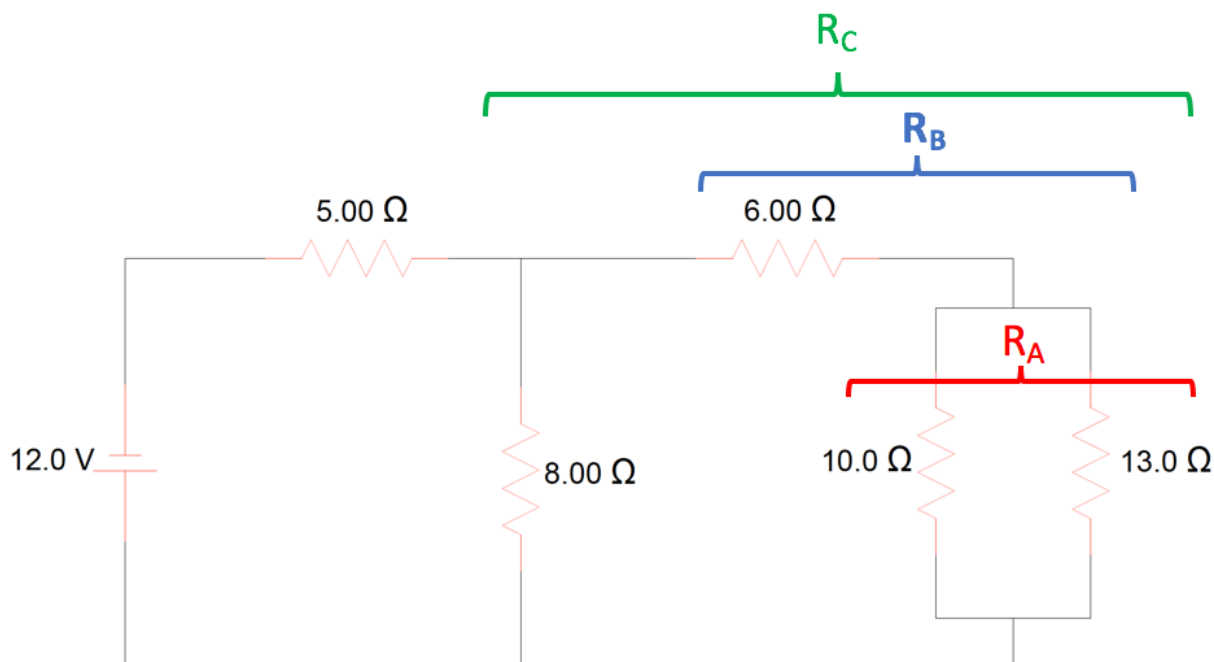

(a) Calculate the total resistance of the circuit.

**(6 marks)**

$$\frac{1}{R_A} = \frac{1}{10} + \frac{1}{13}$$

$$R_A = 5.6522 \Omega$$

**(1 mark working for parallel resistor)****(1 mark answer for parallel resistance)**

$$R_B = 5.6522 + 6.00 = 11.6522 \Omega$$

**(1 mark for solving series resistance)**

$$\frac{1}{R_C} = \frac{1}{11.652} + \frac{1}{8}$$

$$R_C = 4.7434 \Omega$$

**(1 mark working for parallel resistor)****(1 mark answer for parallel resistance)**

$$R_T = 4.7434 + 5.00 = 9.7434 \Omega = 9.74 \Omega$$

**(1 mark solution)**

(b) Calculate the total current flowing through the battery.

(2 marks)

$$I_T = \frac{V_T}{R_T} \quad (0.5 \text{ Equation})$$

$$I_T = \frac{12}{9.7434} \quad (0.5 \text{ Working for } I_T)$$

$$I_T = 1.2316 \text{ A} = 1.23 \text{ A} \quad (1 \text{ mark solving})$$

(c) Calculate the voltage across the 5.00  $\Omega$  and the voltage across the 8.00  $\Omega$  resistor.

(3 marks)

Voltage across 5.00  $\Omega$

$$V = I_T R \quad (0.5 \text{ marks})$$

$$V = (1.2316)(5.00) \quad (0.5 \text{ marks})$$

$$V = 6.1580 = 6.16 \text{ V} \quad (0.5 \text{ marks})$$

Voltage across 8.00  $\Omega$

$$V = V_T - V_{5\Omega} \quad (0.5 \text{ marks})$$

$$V = 12.0 - 6.1580 \quad (0.5 \text{ marks})$$

$$V = 5.8420 = 5.84 \text{ V} \quad (0.5 \text{ marks})$$

(d) Calculate the current through the 10.0  $\Omega$  resistor.

(4 marks)

$$I_B = \frac{V_{8\Omega}}{R_B}$$

$$I_B = \frac{5.8420}{11.6522}$$

$$I_B = 0.5014 \text{ A} \quad (1.5 \text{ marks STEP 1})$$

$$V_A = I_B R_A$$

$$V_A = (0.5014)(5.6522)$$

$$V_A = 2.8338 \text{ V} \quad (1.5 \text{ marks STEP 2})$$

$$I_{10\Omega} = \frac{V_A}{R_{10\Omega}}$$

$$I_{10\Omega} = \frac{2.8338}{10.0} = 0.283 \text{ A}$$

(1 mark final solution)

**END OF TEST**